

# VOIP

Often pronounced “voyp”

*voice over Internet protocol*



# What is VoIP?

VoIP is, or Voice over Internet Protocol, a new form of digital telephone service in which calls are sent and received over the Internet.

To utilize Voice over IP phone systems, all users need is a high speed Internet connection and a VoIP phone service provider.

# VoIP



# VS



# Landline

<https://getvoip.com/blog/2013/06/19/voip-vs-landline/>

Voice over IP phone services include unlimited calling and many free features that you would normally pay for with a traditional phone company, such as call waiting, call forwarding, caller ID, etc.

# How do VoIP phones work compared to a landline phone?

You won't even notice a difference. When making a call using your VoIP phone service, you pick up your phone like normal, dial the number you want to reach, your phone connects to the PSTN, and connect using your internet connection instead of a traditional circuit board landline.

Traditional landlines work by transferring analog voice signals over copper wires.

Voice over IP works by converting analog voice into digital data packets and transmitting it over the internet.

<u>Considerations</u>	<u>VoIP</u>	<u>Landline</u>
Setup cost	Low	High
Running cost	Low	High
KBPS	Needs 10 KBPS	Needs 64 KBPS
Multimedia	Transmit voice, video, and any form of multimedia just like you do on the Internet	No support for multimedia. Only voice
Scalability	Easy and inexpensive to scale as your business grows	Additional phone sets and wired phone lines needed in order to scale.
Add-ons	Large number features available at no additional cost (call waiting, forwarding, call parking, etc.)	Limited options for add-ons, most of which cost extra
Outages	Internet should be functional at all times, but calls can be forwarded to a secondary device during a power outage	Usable during a power outage
Call pricing	Free VoIP to VoIP calls. International and mobile calls typically charged at a nominal rate	No free PSTN to PSTN calls. All calls are charged



Voice over Internet protocol means voice that travels by way of the same protocols used on the Internet..

VoIP is often referred to as *IP telephony* (IPT) because it uses Internet protocols to make possible enhanced voice communications. The Internet protocols are the basis of IP networking, which supports corporate, private, public, cable, and even wireless networks. VoIP unites an organization's many locations — including mobile workers — into a single converged communications network and provides an unparalleled range of telephony support services and features .

In the beginning, there was POTS  
Before digital networking took off,  
everyone had to use the one and only  
POTS (or plain old telephone service —  
honestly!). POTS runs over a network  
called the PSTN, or public switched  
telephone network. These POTS  
telephone systems use the tried-and-  
true method of telephone service  
known as circuit-switched.

# Residential VoIP

Advertisements



**VOIPO HOME PHONE**  
★★★★☆ 45 reviews

- Unlimited Calls to US/Canada
- Over 45 Features + Free 2nd Line
- Free international call allowance

\* \$15.00/mo. or \$6.21/mo. with 2 year contract

**\$ 6.21 / mo. \***  
Set-Up Fee: Free  
Rate/min: \$0.00

[GET QUOTE!](#)



**ITP**  
Unlimited Calling!  
Two Months FREE!

**VOIP PHONE SERVICE**  
★★★★☆ 104 reviews

- 2 months free, any plan
- Phone adapter provided
- No contracts, no cancellation fee

\* \$8.32/mo. with 12-month agreement

**\$ 8.32 / mo. \***  
Set-Up Fee: Free  
Rate/min: \$0.00

[GET QUOTE!](#)



**AXVOICE**  
Internet phone service

**HOME PHONE SERVICE**  
★★★★☆ 53 reviews

- Unlimited USA and Canada calling
- Free hardware and activation
- Money back guarantee, 30+ features

\* \$6.25/mo. 1-year prepay equals \$75.00/year

**\$ 6.25 / mo. \***  
Set-Up Fee: Free  
Rate/min: \$0.00

[GET QUOTE!](#)



**phone power**

**HOME PHONE SERVICE**  
★★★★☆ 158 reviews

- Unlimited calling
- Cellular phone compatible
- 60 free international minutes

\* \$8.33 is monthly average with 1-year prepay

**\$ 8.33 / mo. \***  
Set-Up Fee: Free  
Rate/min: \$0.00

[GET QUOTE!](#)

\*Rates shown do not include E-911 charges, taxes, and surcharges. Most providers offering unlimited calling have restrictions and some rates shown are promotional rates based on term contracts or promotional periods. Be sure to read individual providers terms and conditions before you buy. Rates and features displayed for each provider have been sourced from provider's site and other online sources. While we strive to display current information, be sure to check directly with each provider as their plans, pricing, and features are subject to change.

### VoIPo

Unlimited Calls to US/Canada

Over 45 Features + Free 2nd Line

Free international call allowance

\$15.00/mo. or \$6.21/mo. with 2 year contract

\$ 8.32 /mo. \*

### ITP

2 months free, any plan

Phone adapter provided

No contracts, no cancellation fee

\$8.32/mo. with 12-month agreement

\$ 6.25 /mo. \*

### Axvoice

Unlimited USA and Canada calling

Free hardware and activation

Money back guarantee, 30+ features

\$6.25/mo. 1-year prepay equals \$75.00/year

\$ 8.33 /mo. \*

### Phone Power

Unlimited calling

Cellular phone compatible

60 free international minutes

\$8.33 is monthly average with 1-year prepay

*\*Rates shown do not include E-911 charges, taxes, and surcharges. Most providers offering unlimited calling have restrictions and some rates shown are promotional rates based on term contracts or promotional periods. Be sure to read individual providers terms and conditions before you buy. Rates and features displayed for each provider have been sourced from provider's site and other online sources. While we strive to display current information, be sure to check directly with each provider as their plans, pricing, and features are subject to change.*

## **VoIP: Advantages**

Being VoIP providers ourselves at Nextiva, it would be fair to say we know a thing or two about VoIP. Here's a detailed guide into its pros and cons:

- **Lower costs**
- **Increased accessibility**
- **Complete portability**
- **Higher scalability**
- **Advanced features for small and large teams**
- **Clearer voice quality**
- **Supports multitasking**
- **More flexibility with softphones**

<https://www.nextiva.com/blog/voip-advantages-and-disadvantages.html>

## **VoIP: Disadvantages**

Everything that has an advantage has its disadvantages. VoIP telephony is not exempt from this party rule.

Here are the downsides associated with the VoIP service you need to be aware of:

- **Reliable Internet Connection Required**
- **Latency and Jitter**
- **No location tracking for emergency calls**

<https://www.nextiva.com/blog/voip-advantages-and-disadvantages.html>





## Spectrum Voice Features

Spectrum Voice provides much more than just being able to talk all you want. In addition to unlimited local and long distance calling, Spectrum Voice includes up to 28 of the most popular home phone features.

- Voicemail
- Nomorobo
- Block Outbound Caller ID
- Forward All Calls
- Block Unwanted Callers
- Block Anonymous Calls
- Block International Calls
- Caller ID on TV

\$9.99/month when bundled\*

## Calling Features - Spectrum Voice

- Forward All Calls
- VIP Ring
- Repeat Dialing
- Simultaneous Ring
- Caller ID
- Block Anonymous Calls
- Accept Selected Callers
- Readable Voicemail
- Setup Backup Phone
- Call Waiting
- Forward Selected Calls
- Speed Dial
- Return Call
- Nomorobo
- Call Waiting with Caller ID
- Block Unwanted Callers
- 3-Way Calling
- Caller ID on TV
- Do Not Disturb
- Block International Calls
- Block Outbound Caller ID
- Trace Call
- Block Collect Calls
- Forward Calls When Busy
- Forward Calls When No Answer
- Block 3rd Party Charges
- Block 900/976 Calls

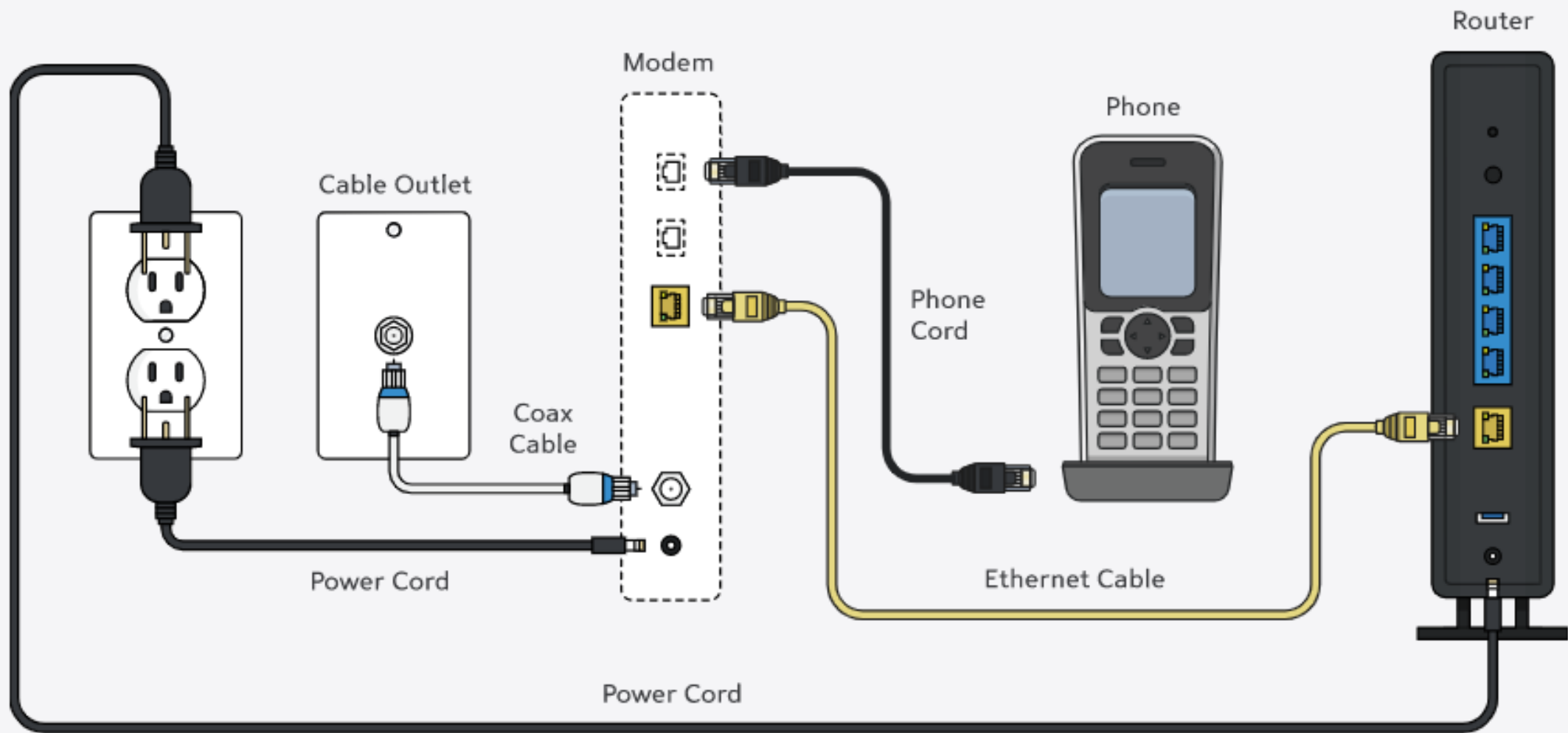



# Google Voice

Google LLC   Communication

**E** Everyone

**i** This app is compatible with all of your devices.

# Google Voice with OBi

Works with Google Voice



Google Voice





You purchased this item on September 1, 2015.

[View this order](#)



VIDEO



## OBi200 1-Port VoIP Phone Adapter with Google Voice and Fax Support for Home and SOHO Phone Service

by Obihai

★★★★★ 3,056 customer reviews

| 953 answered questions

**Amazon's Choice** for "obi200"

List Price: ~~\$89.99~~

Price: **\$46.98** ✓prime | FREE Same-Day

You Save: **\$43.01 (48%)**

Get \$70 off instantly: Pay \$0.00 upon approval for the Amazon Prime Rewards Visa Card.

Service: **Get professional installation** [Details](#)

**Without expert installation**



Roll over image to zoom in

## OBi200 1-Port VoIP Phone Adapter with Google Voice and Fax Support for Home and SOHO Phone Service, Blue

by Obihai

★★★★★ 3,743 ratings | 1000+ answered questions

Amazon's Choice for "obiwifi5g"

Price: **\$69.99** ✓prime & FREE Returns

Get \$100 off instantly: Pay **\$0.00** ~~\$69.99~~ upon approval for the Amazon Prime Rewards Visa Card. No annual fee.

Free Amazon tech support included ▾

Color: **Blue**



Service: **Get professional installation** Details

**Without expert installation**

Include installation  
+\$140.15 per unit

▾ What's included with service

- Works with Google Voice
- Easy to Set-Up Using OBITALK.com. USB for Obihai Accessories OBIWIFI5G and OBiBT
- Also Supports T.38 Fax and SIP Bring Your Own Device Services like Anveo, Callcentric, Voip.ms, etc.
- Works with Up to Four (4) VoIP Services Across One (1) Phone Port
- Call back service present. Application for iphone, ipad, ipod touch and android devices which makes possible placing and receiving calls to/from other OBi endpoints





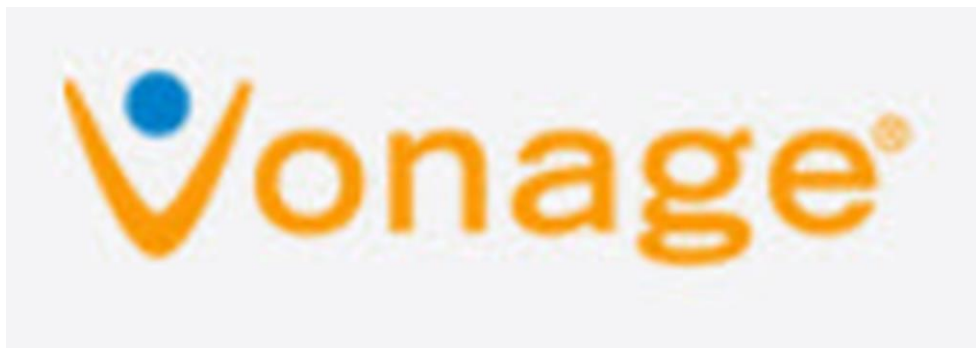

**8x8**



**VoiPLy**

**onsip**

**Dialpad**

# magicJackGO

Home and “On-the-Go” Phone Service

**FREE 12 MONTHS** of service included

**UNLIMITED** local & long-distance calling to the U.S., Canada, Puerto Rico, & the U.S. Virgin Islands

**SAVE** up to \$381 per year!

Only **\$35\***

ADD TO CART

Limited Time Online Offer!





## First time customer?

Start enjoying ultra low-cost VoIP phone service today with a magicJackGO (12 Free Months Included).

GET NOW

[More Info](#)



magicJackGO

## Returning customer?

After your initial service ends, continue enjoying unlimited, crystal clear calls with our flexible, low-cost plans. **Less than \$2.50/mo with our best plans!**

RENEW NOW

Most Popular

\$39

1  
YEAR PLAN

Best Value

\$89

3  
YEAR PLAN



QUESTIONS

A group of ten hands, each holding up a large, three-dimensional blue letter to form the word 'QUESTIONS'. The hands are of various skin tones and are wearing different colored sleeves, including white, light blue, and dark grey. The background is white, and the overall composition is clean and professional.